

### General Description

The XC6206P Series are highly precise, low power consumption, 3 terminal, positive voltage regulators manufactured using CMOS technologies

The XC6206P Series consists of a current limiter circuit, a driver transistor, a precision reference voltage and an error correction circuit. The series is compatible with low ESR ceramic capacitors. The current limiter's foldback circuit operates as a short circuit protection as well as the output current limiter for the output pin.

**SOT-23**



### Features

- Quiescent Current: 8 $\mu$ A
- Input Voltage Range: Max.6V
- Output Current: 300mA
- Low Dropout Voltage: 290mV@100mA (V<sub>OUT</sub>=3.3V)
- Output Voltage: 1.2~5.0V
- Output Voltage Accuracy:  $\pm$ 2% (Typ.)
- Low Power Consumption

**SOT-89**



### Applications

- Mobile Phones
- Battery powered equipment
- Portable game consoles
- Reference voltage sources

### Absolute Maximum Ratings Note1

Ratings at 25°C ambient temperature unless otherwise specified.

Parameter	Symbol	Value	Unit
Input Voltage	V <sub>IN</sub>	-0.3 ~ +6	V
Output Voltage	V <sub>OUT</sub>	-0.3 ~ (V <sub>IN</sub> +0.3)	V
Output Current	I <sub>OUT</sub>	300	mA
Power Dissipation	SOT-23	200	mW
	SOT-23-3	250	mW
	SOT-89	500	mW
Operating Temperature Range	T <sub>opr</sub>	-20 ~ 85	°C
Storage Temperature Range	T <sub>stg</sub>	-55 ~ 125	°C

product model	utput voltage	Output Voltage Accuracy:	Product packaging	Minimum packaging
XC6206P122MR (-G)	1.2V	±2%	MR / SOT--23 MR-G / SOT-23-3	3000
XC6206P152MR (-G)	1.5V	±2%		
XC6206P182MR (-G)	1.8V	±2%		
XC6206P252MR (-G)	2.5V	±2%		
XC6206P282MR (-G)	2.8V	±2%		
XC6206P302MR (-G)	3.0V	±2%		
XC6206P332MR (-G)	3.3V	±2%		
XC6206P362MR (-G)	3.6V	±2%		
XC6206P502MR (-G)	5.0V	±2%		

product model	utput voltage	Output Voltage Accuracy:	Product packaging	Minimum packaging
XC6206P122PR	1.2V	±2%	PR / SOT-89-3L	1000
XC6206P152PR	1.5V	±2%		
XC6206P182PR	1.8V	±2%		
XC6206P252PR	2.5V	±2%		
XC6206P282PR	2.8V	±2%		
XC6206P302PR	3.0V	±2%		
XC6206P332PR	3.3V	±2%		
XC6206P362PR	3.6V	±2%		
XC6206P502PR	5.0V	±2%		

### Ordering Information

### Typical Application Circuit

### Block Diagram

XC6206P- □□□□

Package Type  
MR : SOT-23  
MR-G : SOT-23-3  
PR : SOT-89

Output Voltage Accuracy:  
1 : ±1%  
2 : ±2% Output Voltage  
12 : 1.2V 15 : 1.5V 18 : 1.8V  
25 : 2.5V 28 : 2.8V 30 : 3.0V  
33 : 3.3V 36 : 3.6V 50 : 5.0V

### Electrical Characteristics

(VIN=VOUT+1, CIN=COU=1μF, TA=25°C , unless otherwise noted.)

Parameter	Symbol	Conditions	MIN.	TYP.	MAX.	Unit
Input Voltage	VIN				6	V
Output Voltage Accuracy	ΔVOUT	IOUT=30mA	-2		+2	%
Quiescent Current	IQ	IOUT=0mA		8	15	μA
Dropout Voltage	VDROP	IOUT=100mA, VOUT≤1.5V			570	mV
		IOUT=100mA, 1.8V≤VOUT≤2.5V			420	
		IOUT=100mA, 2.8V≤VOUT≤5V			350	
Line Regulation	ΔVLINE	VIN=VOUT+1 to 6V IOUT=40mA			0.2	V
Load Regulation	ΔVLOAD	1mA<IOUT<80mA		12	30	mV
Output Voltage Temperature Coefficient	TCVOUT	IOUT=30mA, TA=0~70 °C		±100		ppm/°C
PSRR	f=1KHz	PSRR		-70		dB
Output Noise	ENO	BW=10Hz~100KHz		160		μVRMS

Typical Characteristics Curves

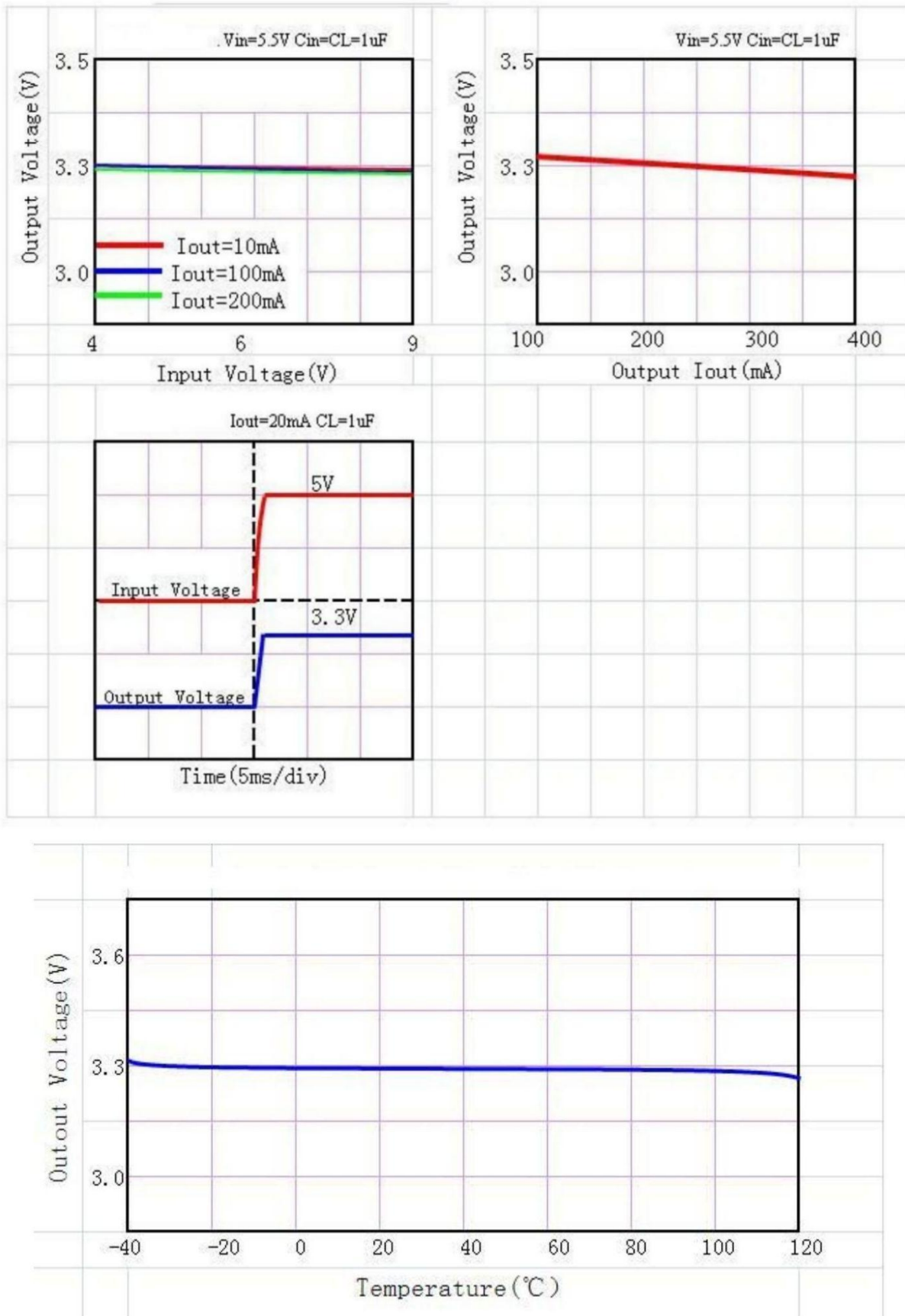

Package Outline

SOT-23

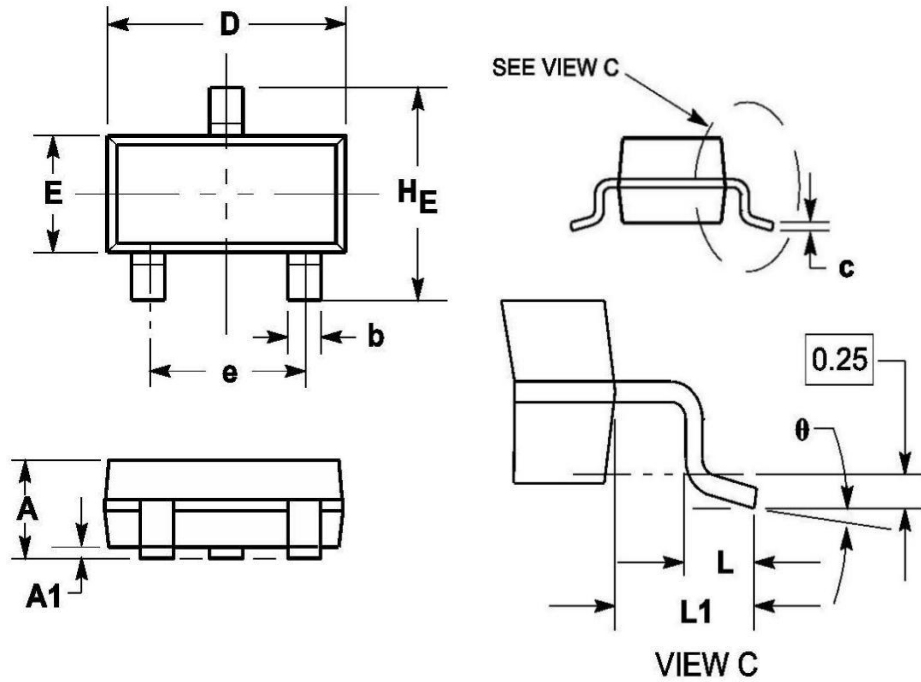

Symbol	Dimensions in millimeter		
	Min.	Typ.	Max.
A	0.900	1.025	1.150
A1	0.000	0.050	0.100
b	0.300	0.400	0.500
c	0.080	0.115	0.150
D	2.800	2.900	3.000
E	1.200	1.300	1.400
HE	2.250	2.400	2.550
e	1.800	1.900	2.000
L1	0.550REF		
L	0.300		0.500
θ	0°		8°

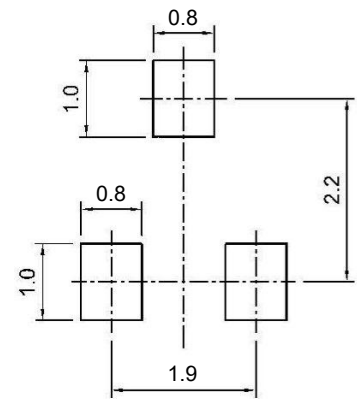

SOT-23

Recommended soldering pad

Package Outline  
 SOT-89  
 Dimensions in mm

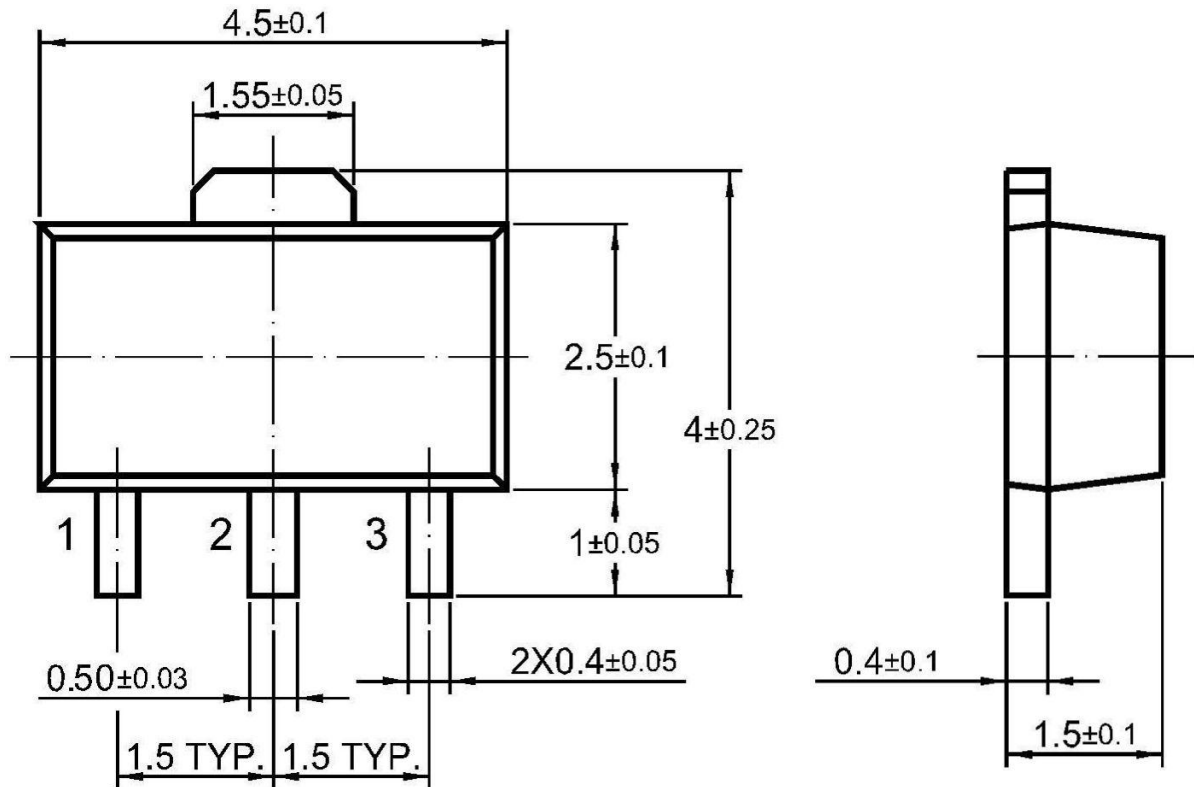

## Attention

- Any and all Anyi Semiconductor products described or contained herein do not have specifications that can handle applications that require extremely high levels of reliability, such as life-support systems, aircraft's control systems, or other applications whose failure can be reasonably expected to result in serious physical and/or material damage. Consult with your Anyi Semiconductor representative nearest you before using any Anyi Semiconductor products described or contained herein in such applications.
- Anyi Semiconductor assumes no responsibility for equipment failures that result from using products at values that exceed, even momentarily, rated values (such as maximum ratings, operating condition ranges, or other parameters) listed in product specifications of any and all Anyi Semiconductor products described or contained herein.
- Specifications of any and all Anyi Semiconductor products described or contained herein stipulate the performance, characteristics, and functions of the described products in the independent state, and are not guarantees of the performance, characteristics, and functions of the described products as mounted in the customer's products or equipment. To verify symptoms and states that cannot be evaluated in an independent device, the customer should always evaluate and test devices mounted in the customer's products or equipment.
- Anyi Semiconductor CO.,LTD. strives to supply high-quality high-reliability products. However, any and all semiconductor products fail with some probability. It is possible that these probabilistic failures could give rise to accidents or events that could endanger human lives, that could give rise to smoke or fire, or that could cause damage to other property. When designing equipment, adopt safety measures so that these kinds of accidents or events cannot occur. Such measures include but are not limited to protective circuits and error prevention circuits for safe design, redundant design, and structural design.
- In the event that any or all Anyi Semiconductor products (including technical data, services) described or contained herein are controlled under any of applicable local export control laws and regulations, such products must not be exported without obtaining the export license from the authorities concerned in accordance with the above law
- No part of this publication may be reproduced or transmitted in any form or by any means, electronic or mechanical, including photocopying and recording, or any information storage or retrieval system, or otherwise, without the prior written permission of Anyi Semiconductor CO.,LTD.
- Information (including circuit diagrams and circuit parameters) herein is for example only ; it is not guaranteed for volume production. Anyi Semiconductor believes information herein is accurate and reliable, but no guarantees are made or implied regarding its use or any infringements of intellectual property rights or other rights of third parties.
- Any and all information described or contained herein are subject to change without notice due to product/technology improvement, etc. When designing equipment, refer to the "Delivery Specification" for the Anyi Semiconductor product that you intend to use.